

Description

The DCSMxxBNP is an uni-directional TVS diode array, utilizing leading monolithic silicon technology to provide fast response time and low ESD clamping voltage, making this device an ideal solution for protecting sensitive semiconductor components from damage. The DCSMxxBNP complies with the IEC 61000-4-2 (ESD) standard with $\pm 30\text{kV}$ air and $\pm 30\text{kV}$ contact discharge. It is assembled into a lead-free SOT-23 package. It is designed to protect components which are connected to data and transmission lines from voltage surges.

Mechanical Characteristics

- ◆ Package: SOT-23
- ◆ Lead Finish: Matte Tin
- ◆ Case Material: "Green" Molding Compound.
- ◆ UL Flammability Classification Rating 94V-0
- ◆ Moisture Sensitivity: Level 3 per J-STD-020
- ◆ Terminal Connections: See Diagram Below
- ◆ Marking Information: See Below

Dimensions and Pin Configuration

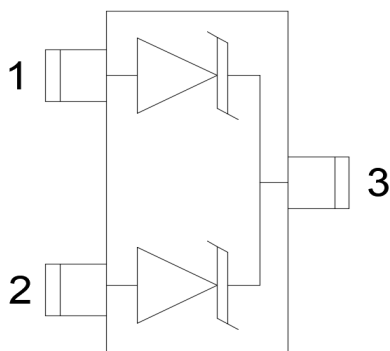

SOT23

Circuit and Pin Schematic

Features

- ◆ 350W peak pulse power(8/20 μs)
- ◆ Protects one bi-directional or two uni-directional lines
- ◆ Ultra low leakage: nA level
- ◆ Operating voltage: 3.3V,5V,8V,12V,15V,24V,36V
- ◆ Low clamping voltage
- ◆ Complies with following standards:
 - IEC 61000-4-2 (ESD) immunity test
 - Air discharge: $\pm 30\text{kV}$
 - Contact discharge: $\pm 30\text{kV}$
 - IEC61000-4-4 (EFT) 40A (5/50ns)
- ◆ RoHS Compliant

Applications

- ◆ Cellular Handsets and Accessories
- ◆ Notebooks and Handhelds
- ◆ Portable Instrumentation
- ◆ Set Top Box
- ◆ Industrial Controls
- ◆ Server and Desktop PC

Marking Information

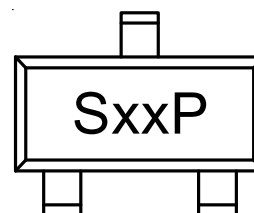

SxxP = Device Marking

xx represents the voltage

Ordering Information

Part Number	Marking	Packaging	Reel Size
DCSMxxBNP	SxxP	3000/Tape & Reel	7 inch

Absolute Maximum Ratings ($T_A=25^{\circ}\text{C}$ unless otherwise specified)

Parameter	Symbol	Value	Unit
Peak Pulse Power(8/20 μs)	Ppk	350	W
ESD per IEC 61000-4-2 (Air)	VESD	± 30	kV
ESD per IEC 61000-4-2 (Contact)		± 30	
Operating Temperature Range	TJ	-55 to +125	$^{\circ}\text{C}$
Storage Temperature Range	Tstg	-55 to +150	$^{\circ}\text{C}$

Electrical Characteristics ($T_A=25^{\circ}\text{C}$ unless otherwise specified)

DCSM03BNP (Marking Code: S03P)						
Parameter	Symbol	Min	Typ	Max	Unit	Test Condition
Reverse Working Voltage	VRWM			3.3	V	
Breakdown Voltage	VBR	4			V	IT = 1mA
Reverse Leakage Current	IR		0.01	0.5	μA	VRWM = 3.3V
Forward Voltage	VF		0.8	1.2	V	IF = 10mA
Clamping Voltage	VC		5		V	I _{PP} = 1A (8 x 20 μs pulse)
Clamping Voltage	VC		10		V	I _{PP} = 32A (8 x 20 μs pulse)
Peak Pulse Current	I _{PP}			32	A	t _P =8/20 μs
Junction Capacitance	CJ			200	pF	VR=0, f=1MHz, Pin 3 to Pin 1 or Pin 3 to Pin 2
Junction Capacitance	CJ			100	pF	VR=0, f=1MHz, Pin 1 to Pin 2

DCSCM05BNP (Marking Code: S05P)						
Parameter	Symbol	Min	Typ	Max	Unit	Test Condition
Reverse Working Voltage	VRWM			5	V	
Breakdown Voltage	VBR	6			V	IT = 1mA
Reverse Leakage Current	IR		0.01	0.5	μA	VRWM = 5V
Forward Voltage	VF		0.8	1.2	V	IF = 10mA
Clamping Voltage	VC		7		V	I _{PP} = 1A (8 x 20μs pulse)
Clamping Voltage	VC		11		V	I _{PP} = 26A (8 x 20μs pulse)
Peak Pulse Current	I _{PP}			26	A	tp=8/20μs
Junction Capacitance	CJ			200	pF	VR=0, f=1MHz, Pin 3 to Pin 1 or Pin 3 to Pin 2
Junction Capacitance	CJ			100	pF	VR=0, f=1MHz, Pin 1 to Pin 2

DCSCM08BNP (Marking Code: S08P)						
Parameter	Symbol	Min	Typ	Max	Unit	Test Condition
Reverse Working Voltage	VRWM			8	V	
Breakdown Voltage	VBR	8.5			V	IT = 1mA
Reverse Leakage Current	IR		0.01	0.5	μA	VRWM = 8V
Forward Voltage	VF		0.8	1.2	V	IF = 10mA
Clamping Voltage	VC		10		V	I _{PP} = 1A (8 x 20μs pulse)
Clamping Voltage	VC		15		V	I _{PP} = 20A (8 x 20μs pulse)
Peak Pulse Current	I _{PP}			20	A	tp=8/20μs
Junction Capacitance	CJ			200	pF	VR=0, f=1MHz, Pin 3 to Pin 1 or Pin 3 to Pin 2
Junction Capacitance	CJ			100	pF	VR=0, f=1MHz, Pin 1 to Pin 2

DCSCM12BNP (Marking Code: S12P)						
Parameter	Symbol	Min	Typ	Max	Unit	Test Condition
Reverse Working Voltage	VRWM			12	V	
Breakdown Voltage	VBR	13.3			V	IT = 1mA
Reverse Leakage Current	IR		0.01	0.5	μA	VRWM = 12V
Forward Voltage	VF		0.8	1.2	V	IF = 10mA
Clamping Voltage	VC		15		V	I _{PP} = 1A (8 x 20μs pulse)
Clamping Voltage	VC		24		V	I _{PP} = 15A (8 x 20μs pulse)
Peak Pulse Current	I _{PP}			15	A	tp=8/20μs
Junction Capacitance	CJ			200	pF	VR=0, f=1MHz, Pin 3 to Pin 1 or Pin 3 to Pin 2
Junction Capacitance	CJ			100	pF	VR=0, f=1MHz, Pin 1 to Pin 2

DCSCM15BNP (Marking Code: S15P)						
Parameter	Symbol	Min	Typ	Max	Unit	Test Condition
Reverse Working Voltage	VRWM			15	V	
Breakdown Voltage	VBR	16.7			V	IT = 1mA
Reverse Leakage Current	IR		0.01	0.5	μA	VRWM = 15V
Forward Voltage	VF		0.8	1.2	V	IF = 10mA
Clamping Voltage	VC		20		V	I _{PP} = 1A (8 x 20μs pulse)
Clamping Voltage	VC		30		V	I _{PP} = 12A (8 x 20μs pulse)
Peak Pulse Current	I _{PP}			12	A	tp=8/20μs
Junction Capacitance	CJ			200	pF	VR=0, f=1MHz, Pin 3 to Pin 1 or Pin 3 to Pin 2
Junction Capacitance	CJ			100	pF	VR=0, f=1MHz, Pin 1 to Pin 2

DCSCM24BNP (Marking Code: S24P)						
Parameter	Symbol	Min	Typ	Max	Unit	Test Condition
Reverse Working Voltage	VRWM			24	V	
Breakdown Voltage	VBR	26.7			V	IT = 1mA
Reverse Leakage Current	IR		0.01	0.5	μA	VRWM = 24V
Forward Voltage	VF		0.8	1.2	V	IF = 10mA
Clamping Voltage	VC		33		V	I _{PP} = 1A (8 x 20μs pulse)
Clamping Voltage	VC		45		V	I _{PP} = 6A (8 x 20μs pulse)
Peak Pulse Current	I _{PP}			6	A	tp=8/20μs
Junction Capacitance	CJ			70	pF	VR=0, f=1MHz, Pin 3 to Pin 1 or Pin 3 to Pin 2
Junction Capacitance	CJ			35	pF	VR=0, f=1MHz, Pin 1 to Pin 2

DCSCM36BNP (Marking Code: S36P)						
Parameter	Symbol	Min	Typ	Max	Unit	Test Condition
Reverse Working Voltage	VRWM			36	V	
Breakdown Voltage	VBR	40			V	IT = 1mA
Reverse Leakage Current	IR		0.01	0.5	μA	VRWM = 36V
Forward Voltage	VF		0.8	1.2	V	IF = 10mA
Clamping Voltage	VC		41		V	I _{PP} = 1A (8 x 20μs pulse)
Clamping Voltage	VC		60		V	I _{PP} = 4A (8 x 20μs pulse)
Peak Pulse Current	I _{PP}			4	A	tp=8/20μs
Junction Capacitance	CJ			40	pF	VR=0, f=1MHz, Pin 3 to Pin 1 or Pin 3 to Pin 2
Junction Capacitance	CJ			20	pF	VR=0, f=1MHz, Pin 1 to Pin 2

Typical Performance Characteristics (TA=25°C unless otherwise Specified)

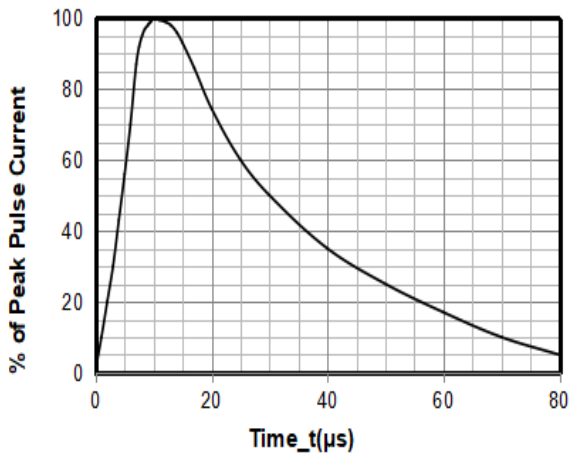

8 X 20μs Pulse Waveform

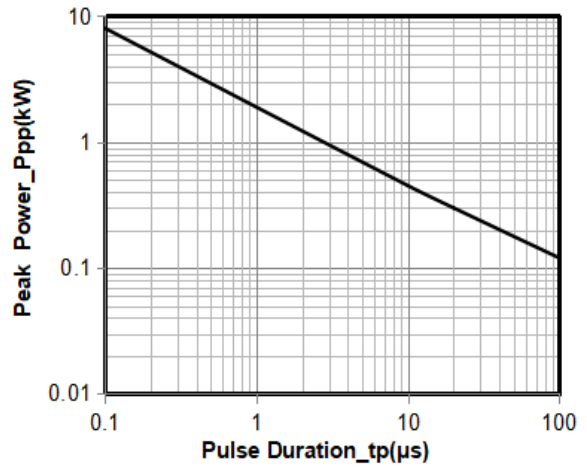

Peak Pulse Power vs. Pulse Time

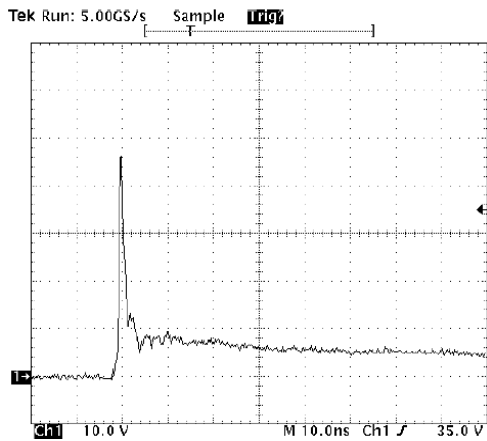

ESD Clamping Voltage

8kV Contact per IEC61000-4-2

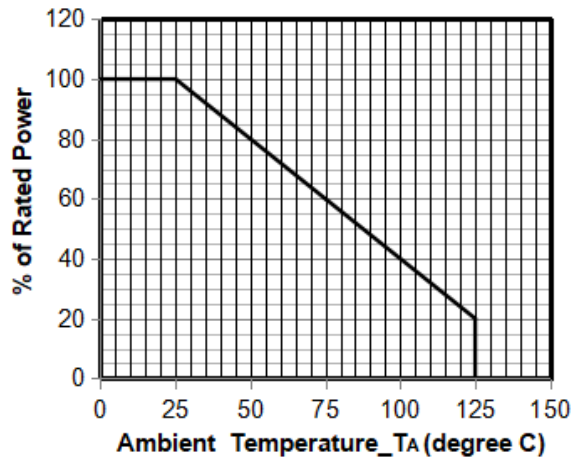

Power Derating Curve

SOT-23 Package Outline Drawing

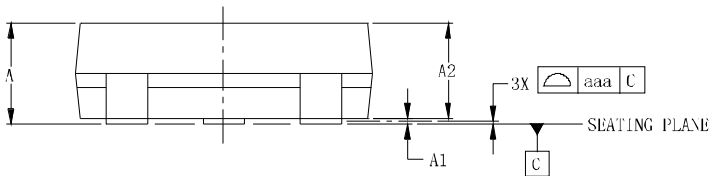
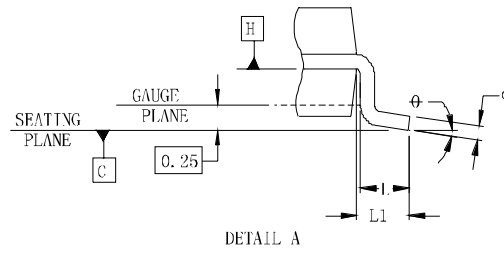
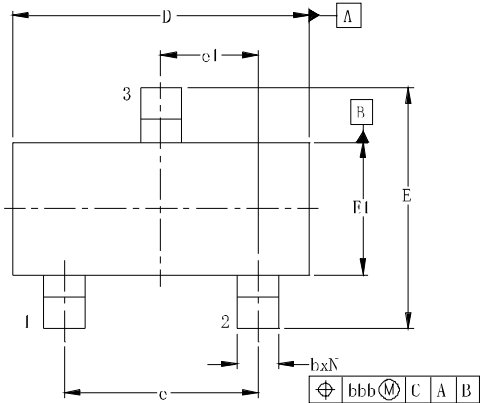

Suggested Land Pattern

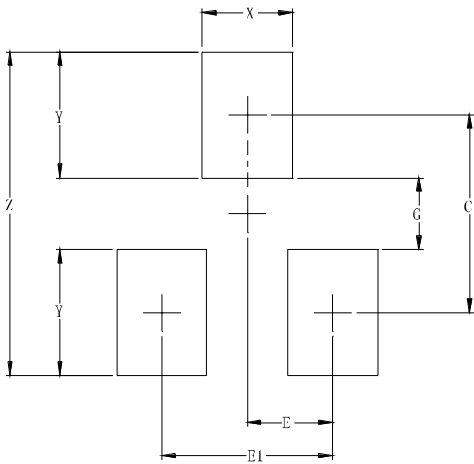

DIMENSIONS						
SYM	INCHES			MILLIMETERS		
	MIN	NOM	MAX	MIN	NOM	MAX
A	0.035	-	0.044	0.89	-	1.12
A1	0.000	-	0.004	0.01	-	0.10
A2	0.035	0.037	0.040	0.88	0.95	1.02
b	0.012	-	0.020	0.30	-	0.51
c	0.003	-	0.007	0.08	-	0.18
D	0.110	0.114	0.120	2.80	2.90	3.04
E	0.082	0.093	0.104	2.10	2.37	2.64
E1	0.047	0.051	0.055	1.20	1.30	1.40
e	0.075			1.90BSC		
e1	0.037			0.95BSC		
L	0.015	0.020	0.024	0.40	0.50	0.60
L1	0.022			0.55		
N	3			3		
ϕ	0°	-	8°	0°	-	8°
aaa	0.004			0.10		
bbb	0.008			0.20		

DIMENSIONS		
SYM	INCHES	MILLIMETERS
C	0.087	2.20
E	0.037	0.95
E1	0.075	1.90
G	0.031	0.80
X	0.039	1.00
Y	0.055	1.40
Z	0.141	3.60

Contact Information

Changzhou D-first Electronics CO.,Ltd.

www.first-electronic.com

Email: xhf@first-electronic.cn

Phone: +86 (0519) 8817 1671